

Bulletin #7153, Understanding Native Bees, the Great Pollinators: Enhancing Their Habitat in Maine

Habitats Series

Understanding Native Bees, the Great Pollinators: Enhancing Their Habitat in Maine

This bulletin was developed by Constance S. Stubbs, research assistant professor, and Nancy Coverstone, Extension educator, the University of Maine.

For information about UMaine Extension programs and resources, visit extension.umaine.edu.

Find more of our publications and books at extensionpubs.umext.maine.edu.

This fact sheet provides information on the native bees in Maine and their habitat requirements. It suggests ways to manage our yards for bees, so that the bees will survive, thrive and reproduce. Food plants, nest sites and appropriate nest materials are critical for enhancing bee habitats.



What Is a Bee?

Bees are insects. Although bees and predaceous hunting wasps evolved from common ancestors, bees do not feed caterpillars, aphids or spiders to their young, as predaceous hunting wasps do. Most bees visit flowers to get pollen and/or nectar, which they use to feed themselves, their offspring and, at times, one another. Pollen is rich in protein, and nectar is rich in sugar, a carbohydrate.

Some bees native to Maine are bright metallic green, others are deep shades of blue, some are red and yellow, and many are deep brown or black. Most bees look furry because they have a dense coat of specialized branched, often feathery, hairs. These hairs help the bee collect pollen. All bees, even those that look like wasps, have some branched hairs. Many bees have also evolved specialized structures for carrying pollen, such as the pollen baskets on the hind legs of honey and bumble bees.

Wasps and flower flies may be mistaken for bees. They often have typical honey or bumble bee coloration—yellow or orange with brown or black in colorful striped patterns. However, flower flies only have two wings, whereas bees and wasps have four. Wasps lack the branched hairs.

Bees Are “Keystone Organisms”

Bees are “keystone organisms” in most terrestrial ecosystems. Bees are essential for maintaining the integrity, productivity and sustainability of many types of ecosystems: the forest understory, pastures, fields, meadows, roadsides, many agricultural crops, fruit orchards, and backyard vegetable and flower gardens. Without bees, many flowering plants would eventually become extinct. Without the work of bees, many fruit- and seed-eating birds and some mammals, including people, would have a less varied and less healthy diet.

As bees forage for food, they pollinate many flowering plants at the same time. While feeding at a flower, a bee may deposit pollen on the flower’s stigma, the receptive part of the plant’s female reproductive organ.

Pollination occurs when the pollen deposited is from the same plant species. For some plant species, pollen can come from the same plant. For others, it must come from a different plant of the same species. The compatible pollen will germinate and fertilize the flower so the plant produces fruit and seeds, from which other plants may grow.

Some plant species have adapted to being pollinated by one or more “agents,” including bats, flies, butterflies and birds (e.g. ruby-throated hummingbirds), as well as wind and water. Overall, however, bees do much of the pollinating in most terrestrial ecosystems worldwide.

Bees are part of the food chain, too. They are a source of protein for some birds, insects and spiders. Skunks, raccoons, bears and some birds also eat bee larvae. For example, a woodpecker foraging on a snag may be feeding on mason or leafcutting bee larvae that are in the dead wood.

Finding the Bees in Your Yard

The most likely place to find bees is in the flowers of native plants, when the day is sunny, relatively calm, and the temperature is above 70°F. To be active, fly and feed, bees need to be warm. A few species are active below 60°, but most prefer temperatures above 72°. Wind makes flying more difficult because it requires more energy.

Although some species may be active by late February if temperatures are unusually warm, the vernal bee species (those present in the spring) generally become active by mid-April. You may observe them on early blooming flowers, such as willow catkins and dandelions. Some native bee species continue their activities into the autumn until the last asters, dandelions and autumn dandelions die. The greatest diversity and abundance of native bees is in midsummer, unless there is a lack of suitable flowers, perhaps because of drought, heavy rains, or how the landscape is managed.

Other places to find native bees are where they nest. Look at the soil along bare banks with a sunny southern exposure. Look in bramble canes, beetle borings in snags, and in abandoned birdhouses. If you do search for bee nests, remember to be cautious for yourself and respectful of them!

Solitary and Social Bees

Most bee species are solitary in terms of interactions with their own kind. There is no worker caste: each female lays eggs and provisions her own nest. A nest may be one cell, or a group of cells, depending on circumstances and opportunity. A cell is the space where an egg is laid and the larval bee develops into an adult. For some solitary species, individuals do not nest near each other. Other solitary species, however, nest close by or next to bees of their own species. Some actually share tunnels, each female having her nest off the same tunnel. When solitary bees do nest near each other, that species is called gregarious. Collections of individual nests are called aggregations.

In contrast, social bees have castes, groups of adults with different functions, so that there is division of labor. Generally, only the queen lays eggs. She is dependent upon the workers, usually sterile females, for her food and for building the nest. The males help to continue the species, adding genetic variability. Social bees live in colonies. Honey bees live in the largest colonies. Bumble bees live in much smaller ones.

Major Families of Bees in Maine

There are more than 270 species of native bees in Maine. Here we provide a brief overview of the major genera in the six bee families found in Maine and mention a few species that you are likely to encounter.

Plasterers, including the yellow-faced bees (family Colletidae)

Colletids (0.3–0.6 inches in length) are called “plasterer, polyester or cellophane bees” because the females line

their brood cells with a cellophane or polyester type substance. In Maine, there are two major genera, *Colletes* and *Hylaeus*.

Colletes species are very hairy. Most are black with white pile on their head and thorax (the middle region of the body that bears the wings and legs). They have conspicuous white stripes on their abdomen. They nest in soil burrows. Occasionally, many bees of these species nest in the same area, forming dense aggregations of burrows in the spring.

Hylaeus, the yellow-faced plasterers, are much smaller than *Colletes*. They are relatively hairless and look more like wasps. Most are black with yellow or white markings on their faces. The yellow-faced plasterers nest in twigs, plant stems and wooden bee nesting houses.

Sweat bees and other halictids (family Halictidae)

Commonly called “sweat bees” because of their attraction to sweat, the Halictidae are generally small, slender bees (0.1–0.5 inches in length). Some species are metallic green, but most are black or brown. They nest in the soil and rotten wood. Some species in this family are solitary nesters, while others are not. Halictids are often found feeding at composite flowers, with a center of tiny true flowers surrounded by rays, such as black-eyed Susans during midsummer and asters during late summer and early fall.

Miner and sand bees (family Andrenidae)

Most *Andrena* are soil nesters, hence the common names of “miner bees” and “sand bees.” If conditions are ideal, some species nest in large aggregations. They are moderately robust (0.3–0.6 inches in length). Most are black; a few species are shades of gray-brown, sometimes with abdominal stripes. The miner bees are among the first bees to emerge in the spring.

Mellitids (family Mellitidae)

Mellitids are uncommon, solitary—but gregarious—soil-dwelling bees. They superficially look like *Andrena*. Two genera are found in Maine: *Melitta* and *Macropis*. The *Macropis* are unusual because the adults feed on nectar but do not collect nectar for their offspring. Instead, the females collect floral oils from loosestrife (e.g. fringed loosestrife, *Lysmachia ciliata*), which they mix with pollen from the same plant.

Leafcutters and masons (family Megachilidae)

The females use leaves, mud and sometimes pebbles in their nest construction. Most are about the same size as those in the family Andrenidae (0.3–0.6 inches in length). In Maine, the two most common genera are *Osmia* and *Megachile*. Some *Osmia* are shades of metallic blue, or blue-black. The *Megachile* are shades of gray-brown, often with abdominal stripes.

Most species in this family are moderately hairy, especially the abdomens of the females. The hairs are an adaptation for collecting pollen to take back to the nest. With a thick layer of pollen coating their bellies, it is easy to identify these females.

Some species of Megachilidae nest in the ground. In Maine, however, most species in this family use old borings in trees made by other insects for their nests. These bees readily accept wooden bee nesting houses. (See our bulletin #2420 for information on the biology and conservation of *Osmia*, which are important pollinators of Maine’s lowbush blueberries.)

Bumble bees (family Apidae)

Bumble bees are social bees and belong to the same family as honey bees, because the females store collected pollen in specialized corbiculae, “pollen baskets,” on their hind legs. Like honey bees, bumble bees

have three castes: queens are the largest (0.5–1 inches long), workers, which are also female but do not lay eggs, are smaller (0.2–0.8 inches long) and males are mid-sized (0.3–0.9 inches long). Bumble bee tongue length varies among species. Bumble bees are very furry and have a robust physique.

Sixteen species of bumble bees are found in Maine. Most North American species are black with yellow markings. *Bombus ternarius*, a common species found throughout the United States and much of Canada, is yellow and orange, and thus aptly known as the orange-belted bumble bee.

Bumble bees visit flowers even in cold, rainy weather and are superior pollinators. Some species live below ground, others above ground, and some have no preference. Nest sites include abandoned rodent nests in undisturbed meadows and pastures, abandoned bird nests, cavities in rock walls, foundations, and other sheltered areas. The impatient bumble bee, *Bombus impatiens*, often nests in foundations and even in insulation in walls and rugs stored in sheds. In Maine, bumble bee colonies rarely have more than 40 individuals.

Bee Life Cycles

Like many other insects, a bee's life develops through a series of four stages: the egg, the larva (the active feeding stage), the pupa (the inactive stage), and the adult. The larval stage in most insects, including bees, is wingless and looks very different from the adult stage. The duration of each stage varies for each species. Here are life cycle descriptions for three native bee species.

Early vernal miner bee, *Andrena dunningi*

This may be the first bee you see in the spring. It is very partial to sunny, south-facing, bare, sandy-clay soil slopes. It is solitary, but gregarious; the nests tend to be in aggregations. Starting in late March in warm years, adult males emerge from the soil before the females, leaving visible holes in the soil. Usually, the males alternate between feeding on flower nectar and waiting for females to emerge so they can mate.

Another sign of miner bees are little mounds of soil with a hole in the center, which indicate where the females are constructing their nests below ground. For about a month, female miner bees forage on nectar and pollen from such flowers as maple, dandelion and crocus. They lay eggs in carefully constructed cells lined with a special waterproof material. In each completed cell, a tiny creamy-white egg sits atop a mass of pollen moistened with a bit of nectar, which the hatching larval bee will feed on. After the larva undergoes several molts, it develops into the pupal stage and finally into the adult stage.

All these development processes happen within each natal cell below ground. The new generation of adult miner bees will remain dormant until the following spring, awaiting warm temperatures and a burst of early spring flowers.



Early vernal miner bee

Blue orchard bee, *Osmia lignaria*

Blue orchard bees overwinter as dormant adults. About the time apple trees begin blooming, the first males appear. The blue orchard bee is a superior pollinator of apples and its relatives in the genus *Malus*.

Mating between males and females usually occurs at the nest site. Males wait by the nest for females to emerge. After mating, the females begin new nest construction. Nest sites may be in previously used insect borings in wood and bramble canes, underneath clapboards or in nail holes. The blue orchard bee is a frequent resident in bee nesting houses.

Each female constructs her own nest. It begins when she starts a cell with a mud partition at one end. Then she forages for pollen and nectar, often from apple blossoms, and makes a pollen-nectar loaf upon which she deposits an egg. She then seals the cell with another mud partition. Within a bramble cane she may make as many as 20 cells, each with an egg. Within a few days, the eggs hatch and the larvae feed until it is time to pupate. By late October, the pupae become adults but remain inactive, each in its cell, until spring when they emerge to resume the cycle of life.

Image reprinted with permission from the Sustainable Agriculture Network (SAN), www.sare.org, from G. Frehner, in Jordi Bosch and William P. Kemp, *How to Manage the Blue Orchard Bee as an Orchard Pollinator* (Beltsville, MD: Sustainable Agriculture Network).

Orange-belted bumble bee, *Bombus ternarius*

The orange-belted bumble bee queen emerges from hibernation in early spring. She must satisfy two immediate needs. She must nourish herself on flower nectar and pollen, and she must find a good place to raise a family. Queens spend hour upon hour cruising just above the ground looking for a suitable nest site underground, often settling in an abandoned mouse burrow.

Once the queen has a nest site and starts secreting sufficient wax, she makes a waxen cell in the center of the nesting area. She lays some eggs in this cell. She also makes a waxen "honey pot" for storing nectar. Usually throughout April and into mid-May each orange-belted queen forages for nectar and pollen for her own survival and to provision the nest for her young. Her first eggs take three to four days to hatch into worm-like larvae that feed voraciously on stored nectar and pollen. After they become pupae, they develop adult tissue for about 14 days and then emerge as beautiful silvery "callow" worker bumble bees. In two to three days, these workers attain their true adult coloration and their wings harden enough for flight.

When enough workers are actively provisioning the nest with nectar and pollen, the queen devotes her time to laying and incubating her eggs and defending the nest against intruders. From the mid- through late summer, the queen lays special unfertilized eggs, which develop into males. Shortly thereafter she switches to producing new queens. Each new queen, after mating, must find a good spot to spend the winter underground. Throughout the winter each queen is dormant in her hibernation cell, waiting for spring to start the cycle again. The workers, males and old mother queen of each colony die by midautumn.

The Pollination Crisis

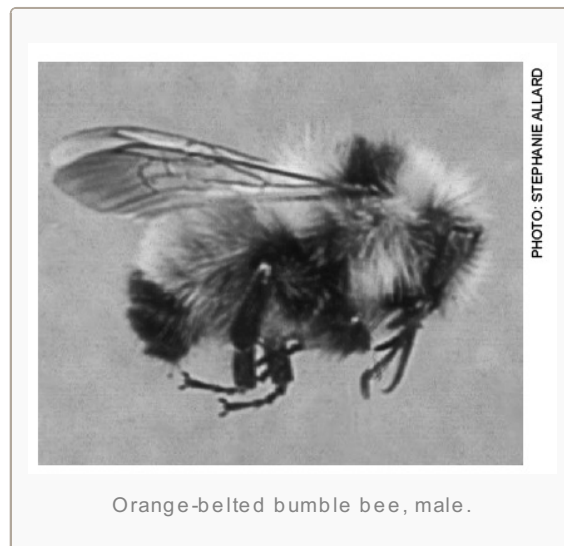
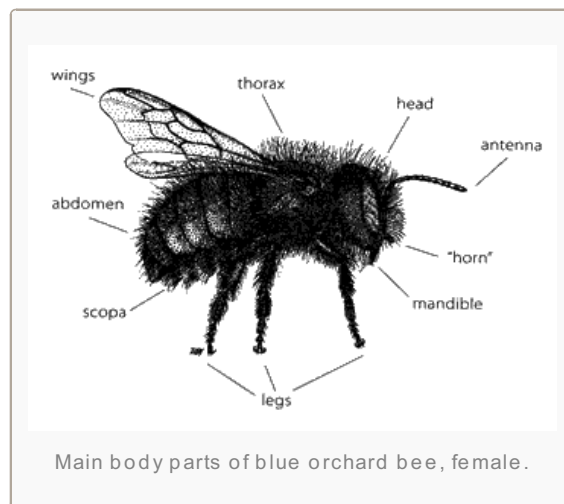

Conservation biologists worldwide are concerned about declines in bee abundance and species diversity. In the United States, honey bees, bumble bees, and approximately 4000 species of solitary bees pollinate agricultural crops and plants of garden, lawn, meadow and forest. Conversion of the landscape to residential and commercial uses eliminates natural bee habitats. Often, the developed landscape is not managed to create or enhance bee life. In addition, many insecticides and herbicides are either toxic to bees or destroy their habitats by killing flowers that provide bees with nectar and pollen. All these factors are contributing to the loss of bee populations and diversity.

Honey bee populations have changed, too. People manage honey bees for crop pollination and honey production because they are social and live in large colonies. However, honey bees are not native to North America. European settlers brought them here in the 17th century. They are one of a few bee species that convert nectar into honey in sufficient amounts for human consumption. Since 1990, managed honey bee populations have decreased by 25 percent due to the ravages of parasitic mites that were unintentionally introduced. Other causes, such as pesticide misuse, further reduce their numbers.

Horticulturalists, conservationists, ecologists and home gardeners are becoming more aware that native bees are important for pollination. However, native bees, with few exceptions, are unmanaged, and little is known about their populations. There are two noteworthy exceptions. In Hawaii, many native bee species are imminently threatened with extinction. And in the wild blueberry fields of Washington County, Maine, six species of native bees were last collected in the mid-1960s. Managing native bees as we manage honey bees, in large hives, is not possible. However, we can enhance the habitats of native bees, providing nest sites and forage plants, to help them to survive, thrive, reproduce and pollinate! Such habitat management benefits honey bees as well.

Cost versus benefit: sting versus pollination

Not all bees sting. No male bees sting. That's a true statement for all the estimated 30,000 species of bees worldwide. Many species are small bees and at worst their sting feels like a pinprick. Sometimes, stings are attributed to bees when in fact wasps, such as yellow jackets, are the culprits.

However, the queen and worker **honey and bumble bees** can give a nasty sting. For a very few of us, their sting can be lethal. For most people, their sting and perhaps accompanying swelling, while painful, is temporary. Consider a world without bees. For most of us, the cost of being stung is a small price to pay for the essential pollination services that bees provide.

Bees sting as a defense against intruders. Within a species, individuals vary in aggressiveness when provoked. Using common sense will prevent most stings. Look into the flower before you sniff its fragrance. If you go barefoot, look where you step. If you see numerous bees going into a crack in the foundation of your shed, simply avoid getting in the flight path around the entrance to their "home." Before mowing, check for bee activity on a sunny warm day, when most bees and wasps are active. Then, mow on a cloudy, cool day to avoid killing bees.

Make Your Yard "Native Bee" Friendly

Perhaps you too have noticed fewer bees in your garden or orchard and are looking for ways to create or improve habitat for them.

- **Choose nonchemical solutions to insect problems.** Most insecticides are highly toxic to bees. For information on nonchemical insect pest management, see our Habitats fact sheet, [Beneficial Insects and Spiders in Your Maine Backyard](#) (bulletin #7150).
- **Curb the "erb."** Avoid using herbicides. The long-term negative health effects of herbicides on humans are not fully known. Tolerate, in fact, appreciate the beauty and usefulness of flowering "weeds"

such as dandelion. Their presence means more variety of nectar and pollen sources for native bees and others, such as butterflies. They help fill gaps in the succession of planted flowers, and add to the variety of flower shapes, colors and scents.

- **Provide a source of pesticide-free water and mud.** A birdbath, dripping faucet or mud puddle works nicely for bees and attracts butterflies and beneficial insects. To assure a clean source of water, change the water in your birdbath frequently, at least once a day. This will also prevent mosquitoes breeding there. Mud is an important nesting material for several bee species.
- **Establish set-asides and hedgerows.** Bees need undisturbed areas for nesting. Hedgerows or a bit of clutter, such as brush piles of sumac or raspberry canes, can make a safe nest area for them. Set-asides may be areas that are not mowed and are left undisturbed. They could be bare ground, preferably with a sunny, southern exposure ideal for certain species' nesting requirements. Lack of appropriate nest sites is a limiting factor on population.
- **Provide conservation bee nesting houses.**
- **Minimize lawn area, or mow less often.** Mowing grass often kills bees. To avoid this, mow when they are not so active, when it's cool, overcast and windy, or late in the evening. Allowing the lawn to revert to a more natural state, by not mowing or reducing the area that is mowed, will result in a profusion of bee forage and more potential nest sites over time. Areas that are not mowed become set-asides and may be colonized by many flowering plants.
- **Maximize flower space and plant species diversity.** Have gardens, fruit-bearing trees and shrubs, thickets and hedgerows of flowering shrubs, and set-aside areas in your yard. This diversity will provide flower shape variety, a greater quantity of pollen and nectar, and a succession of flowering times.
- **Provide a succession of blooming plants throughout the growing season.** Food plants are an essential habitat requirement for bees and must be available early, middle and late season. Some native bees are actively foraging adults by March and others are active until early November. Bumble bees are a good example of the importance of succession blooming. From early spring until late fall they require nectar and pollen; the number of queens a colony produces depends on the number of workers that are produced in midsummer, which in turn depends on the availability of high quality nectar and pollen.
- **Provide a mix of flower shapes to accommodate different bee tongue lengths.** Small bees, such as the halictids, have short tongues; other species have long tongues. Asters and other composites nicely suit short-tongue bees, but tubular flowers with long corollas are only suitable for species with long tongues. Flower size is not an indication of the quality or quantity of nectar.
- **Include lots of purple, blue and yellow flowers in your bee sanctuary.** These are the most attractive colors to bees. Planting the colors in masses will get their attention!
- **Emphasize native perennial plants.** Perennials generally are richer nectar and pollen sources and, because they bloom year after year, they provide a more dependable food source than annuals, which must be replanted each year. Our native bees have evolved with our native plants, to mutual benefit.
- **Avoid horticultural plants, such as marigolds and roses, bred as "doubles."** These plants have been bred for more showy petals in place of anthers. Thus, they have little or no pollen. Also, the many petals often make the nectar physically inaccessible to bees, butterflies, hummingbirds and others.
- **Select sunny locations, sheltered from the wind, for your flower plantings.** Smaller bees, especially, use the sun to help warm their bodies. Also, plants receiving at least six hours of sunlight have more nectar than those receiving less.
- **Remember that early spring and late autumn are very challenging times for bees because of coolness, highly variable temperatures and a lack of flowers.** In the spring, tolerate those dandelions. In the late fall, let the bees and migrating monarch butterflies have the few remaining flowers.

Leaving fallen fruit to rot, such as windfall pears, may help too, but be aware that you will also be attracting hungry wasps.

- **Practice peaceful coexistence.** Bees sometimes choose to nest in inconvenient places. Rather than exterminating them, think of it as an opportunity to see and learn about them up close.

What we do for bees benefits other wildlife species

The flowering herbaceous plants, shrubs and trees used by bees also provide nectar for butterflies, moths, beneficial insects and ruby-throated hummingbirds. They produce seeds and fruits that are eaten by many species of birds and mammals. Hedgerows, thickets, set-asides, trees and snags are habitat components that provide cover and nest sites for many wildlife species. Bees, birds, butterflies, dragonflies and all other wildlife benefit from the absence of insecticides and herbicides in their habitats.

Plants for Native Bees in Maine

Maine has a rich native bee fauna. Many bee species are excellent pollinators of crops such as apple, strawberry, blueberry, tomato, cucumber, squash and pumpkin. However, the blooming crop alone often cannot sustain our native bees. Each species has its own life cycle, timed differently from others, and has differing food, cover and nesting requirements. For these reasons, a wide diversity of plant species and a continuous succession of blooms throughout the season are necessary. Native bees need abundant nectar (for carbohydrate energy) and pollen (a major source of protein) for survival. Be sure to provide both nectar and pollen plants in each bloom period.

Below is a list of some plants known to be attractive to native bees in Maine.¹ It does not include all the plants useful to native bees. Your own observations of other flowers bees visit will allow you to add to this list. Many of the flowers we enjoy around our homes are pollinated by native bees, and so contribute to the nectar and pollen resources available. Many “weeds” and flowering plants that colonize set-aside areas are also excellent food sources.

Note: No plants listed here are invasive exotic species; many are native to Maine. Most plants in this list prefer full sun.

Plant Key: **A** (Annual) **B** (Bulb) **Bi** (Biennial) **P** (Perennial) **S** (Shrub) **T** (Tree)

Common Name	Scientific Name	Nectar, Pollen or Both	Type of Plant
Red Maple	<i>Acer rubrum</i>	Both	T
Shadbush	<i>Amelanchier sp.</i>	Both	T, S
Crocus	<i>Crocus sp.</i>	Pollen	B
Heath	<i>Erica sp.</i>	Both	P
Snowdrop	<i>Galanthus sp.</i>	Both	B
Apple	<i>Malus sp.</i>	Both	T
Daffodil	<i>Narcissus sp.</i>	Pollen	B
Pieris	<i>Pieris sp.</i>	Both	S
Plum and Cherry	<i>Prunus sp.</i>	Both	T

Red Oak	<i>Quercus rubra</i>	Pollen	T
Willow	<i>Salix sp.</i>	Both	T
Dandelion	<i>Taraxacum officinale</i>	Both	P
Tulip	<i>Tulipa sp.</i>	Pollen	B
Blueberry	<i>Vaccinium sp.</i>	Both	S
Johnny Jump-Up	<i>Viola tricolor</i>	Nectar	P

Common Name	Scientific Name	Nectar, Pollen or Both	Type of Plant
Anise Hyssop	<i>Agastache foeniculum</i>	Nectar	A*
Chives	<i>Allium schoenoprasum</i>	Nectar	P
Borage	<i>Borago officinalis</i>	Both	A
Purple Coneflower	<i>Echinacea purpurea</i>	Both	P
St. John's Wort	<i>Hypericum perforatum</i>	Both	P
Sheep Laurel, Lambkill	<i>Kalmia angustifolia</i>	Pollen	S
Bee Balm	<i>Monarda didyma</i>	Nectar	P
Evening Primrose	<i>Oenothera biennis</i>	Both	Bi
Oregano	<i>Origanum vulgare</i>	Both	P
Self-Heal	<i>Prunella vulgaris</i>	Both	P
Rose	<i>Rosa sp.</i>	Pollen	S
Lamb's Ear	<i>Stachys byzantina</i>	Nectar	P
Dandelion	<i>Taraxacum officinale</i>	Both	P
Thyme (Creeping)	<i>Thymus sp.</i>	Both	P
Red Clover	<i>Trifolium pratense</i>	Nectar	P
* In much of Maine			

Common Name	Scientific Name	Nectar, Pollen or Both	Type of Plant
Aster	<i>Aster sp.</i>	Both	P
Autumn Dandelion	<i>Leontodon sp.</i>	Both	A
Goldenrod	<i>Solidago sp.</i>	Both	P
Meadowsweet	<i>Spiraea alba</i>	Nectar	S

Conservation Bee Nesting Houses²

Construction, placement and maintenance

Placing wooden bee nesting houses in your yard, garden, and around woodland edges is an effective means of increasing populations of cavity-nesting bees, especially mason and leafcutting bees. Several designs are available for purchase, so just follow the placement and maintenance recommendations offered in this fact sheet.

If you have woodworking skills, make your own nesting houses. The design described in this fact sheet is an adaptation of the conservation bee nesting houses used in research, modified for the tools that homeowners would have on hand.

Materials needed

- An 8-foot 2x6 makes 15 (6 1/4-inch) houses, which is more than enough houses for a quarter-acre lot. Bee houses can be made from soft or hard woods. Spruce 2x6s work well. Do not use pressure-treated wood.
- Metal 3/4-inch perforated strapping (also called plumber's strapping or plumber's tape).
- 1-inch or 1 1/4-inch screws for attaching the perforated strapping to the back of the bee houses.
- 3/4-inch screws if houses are attached to wood stakes, or 1 to 1 1/4-inch screws if houses are to be attached to the side of a shed or barn or to fence posts.
- 5-foot wood stakes. Two relatively inexpensive stakes can be made from a 10-foot piece of ceiling strapping.

Tools needed

- Power drill
- Drill bits with 9/64-inch, 5/16-inch and 7/16-inch diameters
- Screw bit or screwdriver
- Circular saw or hand saw
- A sledge hammer if bee houses will be mounted on wooden stakes

Bee nesting house construction

1. **Saw the 2x6s into 6 1/4-inch lengths.**
2. **Drill 7 holes, in a zigzag pattern, into one end of each block.** This will be the "front" of the nest house. If you are using a hand-held power drill, only **7 holes** should be drilled in a 2 x 6 house. The zigzag pattern of the 7-hole configuration is shown in the template in [Figure 4](#). You can trace it onto stiff cardboard or on a quarter-inch sheet of plywood to make a sturdy template. In each house, use at least **two of the three recommended** bit diameters, **9/64-inch, 5/16-inch and 7/16-inch**. All three drill bit diameters may be used in one house. If you have a drill press, you can drill 14 holes in a house. See [Figure 1](#) with the two parallel, vertical rows of holes. Larger nest houses, with more than 16 tunnels, are not recommended because they are more noticeable to parasites and predators. If you use drill bits that are longer than standard, be sure the holes are no deeper than 4 3/4 inches. Each hole will become a nesting tunnel. The space between nesting tunnels is important so bees have a place to land before walking into the tunnel. The different diameter tunnels will be used by different species of bees. The

9/64-inch diameter tunnels attract small bees. The 5/16-inch diameter tunnels attract medium-sized bees. The 7/16-inch diameter tunnels attract larger bees, such as the blue orchard bee. Be careful not to drill completely through the house because adult female bees will not nest in tunnels that are open at both ends. Research in Maine has not included the 9/64-inch diameter tunnels. You may or may not have the small bee species that use this size tunnel present in your landscape. The only way you will know is to include this size tunnels in your bee nest houses, and watch to see if they are used.

3. **Cut the perforated strapping into 3-inch lengths.** Screw the piece of perforated strapping to the back of the wooden house, about 1 inch from the top, using 1 or 1 1/4-inch screws. See [Figure 2](#). Be careful not to screw through a tunnel! The two inches of tape that extends beyond the top is screwed to a stake (use a 3/4-inch screw), fence post or shed (use a 1 or 1 1/4-inch screw).

Note: Use only thoroughly seasoned wood to avoid "nest dry out." As green wood dries, moisture will be removed from any nests in the tunnels, killing the bee eggs and larvae. If you start with green wood, be sure to season the cut pieces by leaving them outdoors in the sun for three days before drilling the holes. If you buy a 2x6 from the lumber store, it will be ready to use when you get it home

Figure 2.

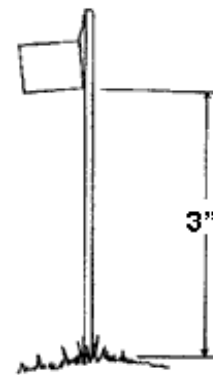
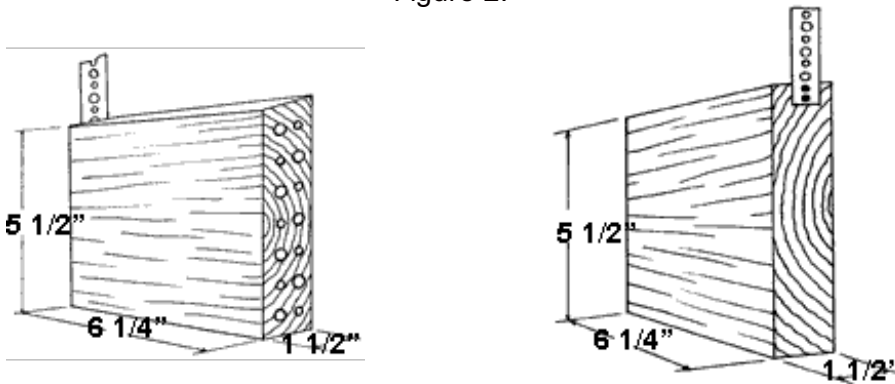
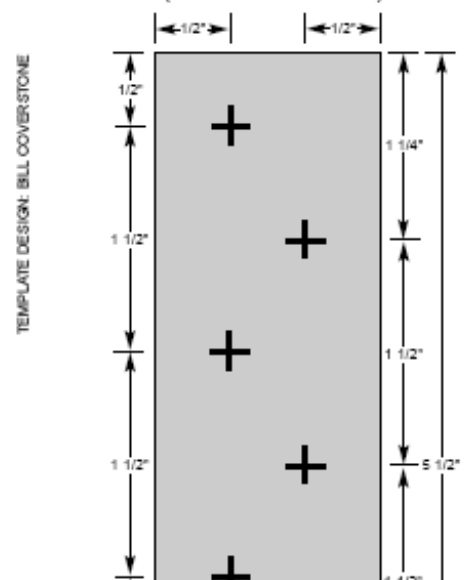

Figure 3.

Placement

- Mid-March to late April is the best time to set the houses if you want to attract *Osmia*, because they emerge and start searching for nest sites in May. You may set the houses as late as mid-September and get some nesting in warm autumns.
- **East, southeast** is the preferred exposure for the front of the house and the tunnel entrances. Hang the houses at a slight **downward angle** to prevent rain from flooding the tunnels.
- The houses should be **3 to 5 1/2 feet above the ground**, so snow will not cover the blocks in winter. This avoids prolonged wetness and possible growth of fungi. (See [Figure 3](#).) Stakes are recommended. Research shows more bee nests are made in bee houses that are on stakes. Also, other insects and spiders make fewer nests in wooden bee nesting houses on stakes. If you use stakes, the bottom of the bee

Template for Bee Nesting House
(drawn to actual size)



house should be 3 feet above the ground. The houses can also be placed on fence posts or the sides of outbuildings, with the bottom of the bee houses at least 3 feet above the ground.

- Native bees do not fly great distances, so the houses need to be relatively close to suitable leaf or soil material for their nests and within 50 yards of their nectar and pollen flowers.
- Nesting houses on stakes can be placed around the yard or garden, from 3 to 10 feet apart. If you are using them in a large-scale agricultural or orchard setting, they should face into the field or orchard and be spaced 10 to 25 feet apart.

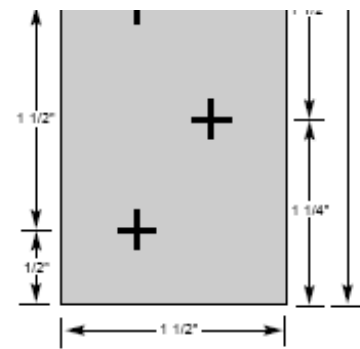

Figure 4

Checking the bee nesting houses for bee nests

Some bee species are pollinating and building nests at the onset of blueberry and apple bloom in late May. You may see female bees flying back and forth laden with pollen, entering a tunnel where they deposit the pollen into each cell. After the completion of each cell, you may see them entering the tunnel with leaf or mud material to seal it off from siblings. The tunnels with completed nests are capped with masticated plant material or mud. Freshly made nest caps of leafcutting bees begin as bright green, but darken with age so that by autumn nest caps are grayish brown or almost brown-black. Various species of bees may be building nests in the bee houses throughout the summer and into September. Each capped tunnel may contain as many as 16 offspring. Under ideal conditions, a female is capable of producing approximately 30 to 36 bees.

Maintenance and replacement

Wooden nesting houses, like tractors and tillers, are equipment and they need periodic maintenance to give best results. Softwood houses generally last four to five years, hardwood ones much longer. The houses need to be checked at least twice a year—in the fall and in the early spring. If any have fallen off the trees or stakes, simply reattach them.

The houses become part of the habitat, and other kinds of wildlife will use them to forage for food or as nest sites. Woodpeckers and some other birds may prey on nesting bees and damage the nesting houses. Always remove any damaged houses and replace them with new ones.

Spiders, some ants, and beneficial wasps will use the wooden bee nesting houses for shelter and nest sites. Wasp nests are also capped with mud. Usually it is not until the third year of use that competition for tunnels becomes noticeable. *When you notice that more than half of the tunnels are capped with materials other than masticated leaf or mud, it is time to add new nesting houses to those already in the habitat.*

¹ List derived from research at the Penobscot County Master Gardeners' pollinator garden, the University of Maine's Rogers Farm, Stillwater, Maine and from Stubbs, et al., *Alternate Forage Plants for Native (Wild) Bees Associated with Lowbush Blueberry, Vaccinium spp. in Maine*, Technical bulletin #148 (Orono: Maine Agricultural and Forest Experiment Station, 1992).

²We know that populations of certain species of native bees increase when conservation bee nesting houses are provided in areas where their other habitat resources are present. For four years, populations of native bees were monitored in fields that were provided with conservation bee nesting houses and in fields without bee houses. Fields that had bee houses showed an increase in populations as compared to the fields without bee houses. (Research conducted by Frank Drummond and Constance S. Stubbs in the Biological Sciences Department of the University of Maine.)

Special thanks to our contributors:

Bill Coverstone, woodworking instructor, Portland Arts and Technology High School, for adapting the bee nesting house design for construction by homeowners

Jim Philp, Extension forestry specialist—Wood Technology, for his work on the section Conservation Bee Nesting Houses

Lois Berg Stack, Extension ornamental horticulture specialist, for her work on the plant list in this fact sheet

Sincere appreciation to our reviewers for their time, suggestions and encouragement:

Stephen L. Buchmann, Ph.D., president, The Bee Works, Tucson, Arizona

Pamela Coffin, master gardener volunteer in Androscoggin/Sagadahoc Counties, Auburn

Frank Drummond, professor of insect ecology/entomology, University of Maine, Orono

Howard Ginsberg, ecologist, United States Geological Survey, Patuxent Wildlife Research Center

Lois Berg Stack, Extension ornamental horticulture specialist, University of Maine, Orono

Information in this publication is provided purely for educational purposes. No responsibility is assumed for any problems associated with the use of products or services mentioned. No endorsement of products or companies is intended, nor is criticism of unnamed products or companies implied.

© 2004

Published and distributed in furtherance of Cooperative Extension work, Acts of Congress of May 8 and June 30, 1914, by the University of Maine and the U.S. Department of Agriculture cooperating. Cooperative Extension and other agencies of the USDA provide equal opportunities in programs and employment. **Call 800-287-0274 or TDD 800-287-8957 (in Maine), or 207-581-3188, for information on publications and program offerings from University of Maine Cooperative Extension, or visit extension.umaine.edu.**

The University of Maine does not discriminate on the grounds of race, color, religion, sex, sexual orientation, including transgender status and gender expression, national origin, citizenship status, age, disability, genetic information or veteran's status in employment, education, and all other programs and activities. The following person has been designated to handle inquiries regarding non-discrimination policies: Director, Office of Equal Opportunity, 101 North Stevens Hall, 581-1226.